



Intel® NUC Board Element CMB2GB Product Specification

Revision 1.1

Regulatory Model: CM2GB

September 2023

Intel® NUC Board Element CMB2GB may contain design defects or errors known as errata that may cause the product to deviate from published specifications. Current characterized errata, if any, are documented in this product specification.

Revision History

Revision	Revision History	Date
1.0	First Release	April 2021
1.1	Updated Figure 2 to show pin one of connector G	September 2023

Disclaimer

This product specification applies only to the standard Intel® NUC Board Element CMB2GB.

INFORMATION IN THIS DOCUMENT IS PROVIDED IN CONNECTION WITH INTEL® PRODUCTS. NO LICENSE, EXPRESS OR IMPLIED, BY ESTOPPEL OR OTHERWISE, TO ANY INTELLECTUAL PROPERTY RIGHTS IS GRANTED BY THIS DOCUMENT. EXCEPT AS PROVIDED IN INTEL'S TERMS AND CONDITIONS OF SALE FOR SUCH PRODUCTS, INTEL ASSUMES NO LIABILITY WHATSOEVER, AND INTEL DISCLAIMS ANY EXPRESS OR IMPLIED WARRANTY, RELATING TO SALE AND/OR USE OF INTEL PRODUCTS INCLUDING LIABILITY OR WARRANTIES RELATING TO FITNESS FOR A PARTICULAR PURPOSE, MERCHANTABILITY, OR INFRINGEMENT OF ANY PATENT, COPYRIGHT OR OTHER INTELLECTUAL PROPERTY RIGHT. UNLESS OTHERWISE AGREED IN WRITING BY INTEL, THE INTEL PRODUCTS ARE NOT DESIGNED NOR INTENDED FOR ANY APPLICATION IN WHICH THE FAILURE OF THE INTEL PRODUCT COULD CREATE A SITUATION WHERE PERSONAL INJURY OR DEATH MAY OCCUR.

All Intel® NUC Board Elements are evaluated as Information Technology Equipment (I.T.E.) for use in personal computers (PC) for installation in homes, offices, schools, computer rooms, and similar locations. The suitability of this product for other PC or embedded non-PC applications or other environments, such as medical, industrial, alarm systems, test equipment, etc. may not be supported without further evaluation by Intel.

Intel Corporation may have patents or pending patent applications, trademarks, copyrights, or other intellectual property rights that relate to the presented subject matter. The furnishing of documents and other materials and information does not provide any license, express or implied, by estoppel or otherwise, to any such patents, trademarks, copyrights, or other intellectual property rights.

Intel may make changes to specifications and product descriptions at any time, without notice.

Designers must not rely on the absence or characteristics of any features or instructions marked "reserved" or "undefined." Intel reserves these for future definition and shall have no responsibility whatsoever for conflicts or incompatibilities arising from future changes to them.

Intel processor numbers are not a measure of performance. Processor numbers differentiate features within each processor family, not across different processor families: Go to:

[Learn About Intel® Processor Numbers](#)

Intel® NUC Board Elements may contain design defects or errors known as errata, which may cause the product to deviate from published specifications. Current characterized errata are available on request.

Contact your local Intel sales office or your distributor to obtain the latest specifications before placing your product order.

Intel, the Intel logo and Intel Core are trademarks of Intel Corporation in the U.S. and/or other countries.

* Other names and brands may be claimed as the property of others.

Copyright © 2023 Intel Corporation. All rights reserved.

Preface

This Product Specification specifies the layout, components, connectors, power and environmental features for the Intel® NUC Board Element CMB2GB.

Intended Audience

This document is intended to provide technical information about Intel® NUC Board Element CMB2GB and its components to the vendors, system integrators, and other engineers and technicians who need this level of information. It is specifically *not* intended for general audiences.

What This Document Contains

Chapter	Description
1	A description of the NUC Board Element CMB2GB
2	A technical description of the NUC Board Element CMB2GB

Typographical Conventions

This section contains information about the conventions used in this specification. Not all of these symbols and abbreviations appear in all specifications of this type.

Notes, Cautions, and Warnings



NOTE

Notes call attention to important information.



CAUTION

Cautions are included to help you avoid damaging hardware or losing data.

Other Common Notation

#	Used after a signal name to identify an active-low signal (such as USBP0#)
GB	Gigabyte (1,073,741,824 bytes)
GB/s	Gigabytes per second
Gb/s	Gigabits per second
KB	Kilobyte (1024 bytes)
Kb	Kilobit (1024 bits)
kb/s	1000 bits per second
MB	Megabyte (1,048,576 bytes)
MB/s	Megabytes per second
Mb	Megabit (1,048,576 bits)
Mb/s	Megabits per second
TDP	Thermal Design Power
Xxh	An address or data value ending with a lowercase h indicates a hexadecimal value.
x.x V	Volts. Voltages are DC unless otherwise specified.
*	This symbol is used to indicate third-party brands and names that are the property of their respective owners.

Intel® NUC Board Element Information

NUC Board Element CMB2GB Identification Information

AA Revision	Product Code	Notes
M10098-302	BKCMB2GB	1

Notes:

1. The AA number is found on the 300-pin connector.

Specification Changes or Clarifications

The table below indicates the Specification Changes or Specification Clarifications that apply to the Intel® NUC Board Element BKCMB2GB.

Specification Changes or Clarifications

Date	Type of Change	Description of Changes or Clarifications

Errata

Current characterized errata, if any, will be documented in Section 3 of this Product Specification.

Contents

Revision History	ii
Disclaimer	ii
Preface	iii
Intended Audience.....	iii
What This Document Contains	iii
Typographical Conventions	iii
Intel® NUC Board Element Information.....	iv
Specification Changes or Clarifications.....	iv
Errata.....	iv
Contents	v
1 Product Description	7
1.1 Overview	7
1.2 Feature Summary.....	7
2 Technical Reference	9
2.1 Block Diagram.....	9
2.2 Features.....	10
2.3 USB 2.0 Headers.....	11
2.4 Fan Headers.....	11
2.5 Power Input Connector.....	11
2.6 Embedded DisplayPort Connector.....	12
2.7 Power Jack.....	14
2.8 Front Panel Header.....	14
2.9 Power.....	14
2.10 Wireless Enable/Disable Switch.....	15
2.11 Thunderbolt™ 4	16
2.12 Intel® vPro® Technology	16
2.13 Thermal	16
2.14 Mechanical	17
2.15 Environmental	18
3 Characterized Errata	19
 Figures	
Figure 1. Block Diagram.....	9
Figure 2. Features (Top).....	10
Figure 3. Features (Bottom)	10
Figure 4. Wireless Enable/Disable Switch Location.....	15

Figure 5. CMB2GB Dimensions..... 17

Tables

Table 1. Feature Summary 7
Table 2. Features..... 11
Table 3. USB 2.0 Header Pinout..... 11
Table 5. Fan Header Pinout 11
Table 6. Power Input Connector Pinout..... 12
Table 4. eDP Connector Pinout..... 13
Table 7. Front Panel Header Pinout..... 14
Table 8. Wireless Enable/Disable Switch Settings..... 16
Table 9. Environmental Specifications 18

1 Product Description

1.1 Overview

The Intel® NUC Board Element CMB2GB is a board only solution for the Intel® NUC Compute Element and consists of a connector for the NUC Compute Element to plug into along with input/output connectors and headers. The Intel® NUC Board Element CMB2GB requires a compatible Intel® NUC Compute Element to operate. For information on compatible devices for use with the Intel® NUC Board Element CMB2GB see <http://www.intel.com/NUCElements>.



NOTE

The Intel® NUC Board Element CMB2GB has been certified for use as a component in Information Technology Equipment in certain countries. The system integrator is responsible for testing and acquiring any additional country-specific regulatory approvals, including all system-wide certifications.

1.2 Feature Summary

Table 1 summarizes the major features of the Intel® NUC Board Element CMB2GB.

Table 1. Feature Summary

Board Size	110 millimeters by 80 millimeters by 1.6 millimeters
Graphics	<ul style="list-style-type: none"> • One HDMI* 2.0b connector on the back panel • One HDMI 2.0b connector on the board edge • One Type C supporting DP 1.4a on the back panel • One eDP 1.4b¹ connector on the board edge • High-Bandwidth Digital Content Protection 2.3 support for content protection • DP1.4a – Up to 5120x3200x60Hz resolutions and refresh rates supported • HDMI 2.0b - Up to 4K @ 60 Hz resolutions and refresh rates supported
Audio	Intel® High Definition (Intel® HD) Audio via HDMI or DisplayPort
Storage	A single M.2 2280 Connector supporting PCIe x4 Gen4 ² NVMe storage
USB	<ul style="list-style-type: none"> • Four USB 3.x³ Ports on the back panel • Two USB 2.0 headers
Thunderbolt™	One Thunderbolt™ 4 (Type-C ⁴ , USB4, DP 1.4a) port on the back panel
Front Panel Header	Single 1x10 header
Wired LAN	<ul style="list-style-type: none"> • Intel® Ethernet Connection i219-LM • One RJ-45 jack on the back panel • Support for Intel® vPro™ Technology (When using a vPro™ enabled NUC Compute Element)
Wireless LAN	Intel® NUC Compute Element supplies the solution, antennas will be required
Power Input	12-24 V DC
Compute Module Connector	Lotes APCI0468-P001A01 Edge Mount Connector

¹ eDP 1.4x is determined by the Intel® NUC Compute Element.

² PCIe x4 speed is determined by the Intel® NUC Compute Element.

³ USB 3.x port speed is determined by the Intel® NUC Compute Element.

⁴ The Type-C port is only operational when an Intel® NUC Compute Element with Thunderbolt™ 4 support is connected.

To find information about...

Intel® NUC Compute Element
Intel® NUC Board Element Support
Intel® NUC Element Warranty Information
Available configurations for Intel® NUC Board
Compute Element
Intel Processors
Intel Graphics
Intel Thunderbolt™ Technology
Intel Wireless
Intel Technologies

Visit this World Wide Web site:

<https://www.intel.com/ComputeElements>
<https://www.intel.com/ComputeElementsSupport>
<http://www.intel.com/NUCWarranty>
<https://ark.intel.com>

<https://www.intel.com/processors>
<https://www.intel.com/graphics>
<https://www.intel.com/thunderbolt>
<https://www.intel.com/wireless>
<https://www.intel.com/technology>

2 Technical Reference

2.1 Block Diagram

Figure 1 is a block diagram of the major functional areas of Intel® NUC Board Element CMB2GB.

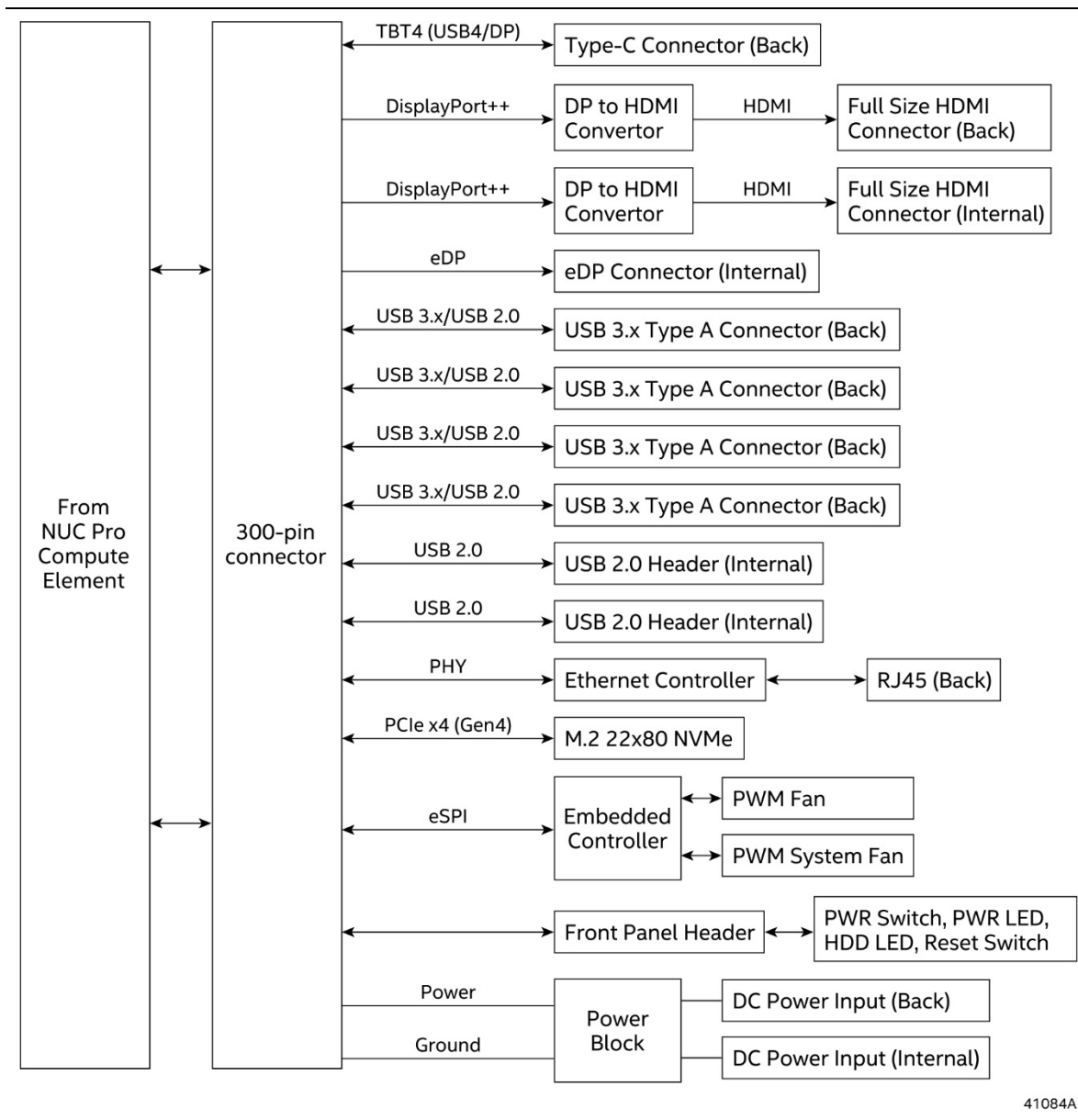

41084A

Figure 1. Block Diagram

2.2 Features

The NUC Board Element CMB2GB has a 300-pin edge connector. Each side of the board and the back panel have input/output connectors and headers. See the below figures for the locations of the connectors, headers and switches.

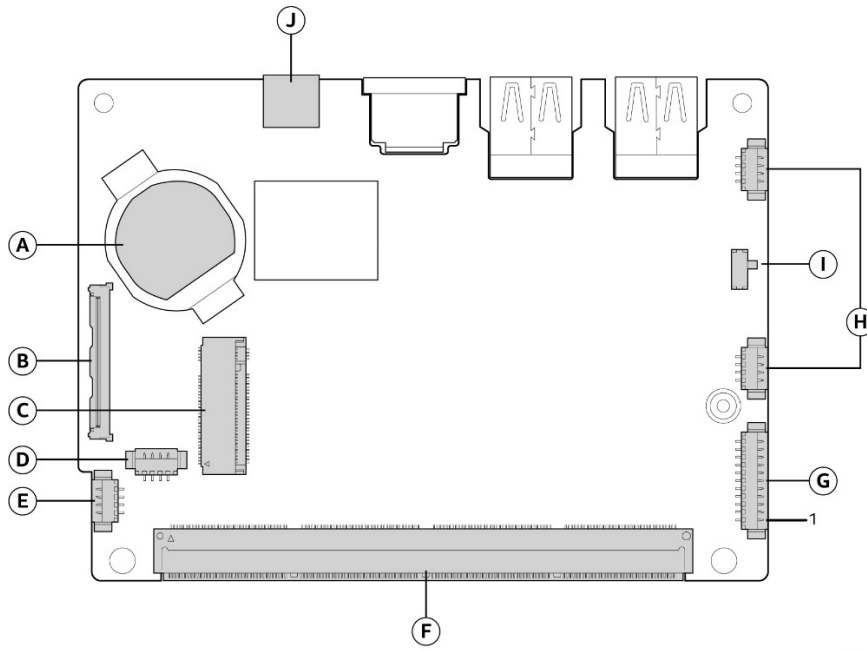

41089

Figure 2. Features (Top)

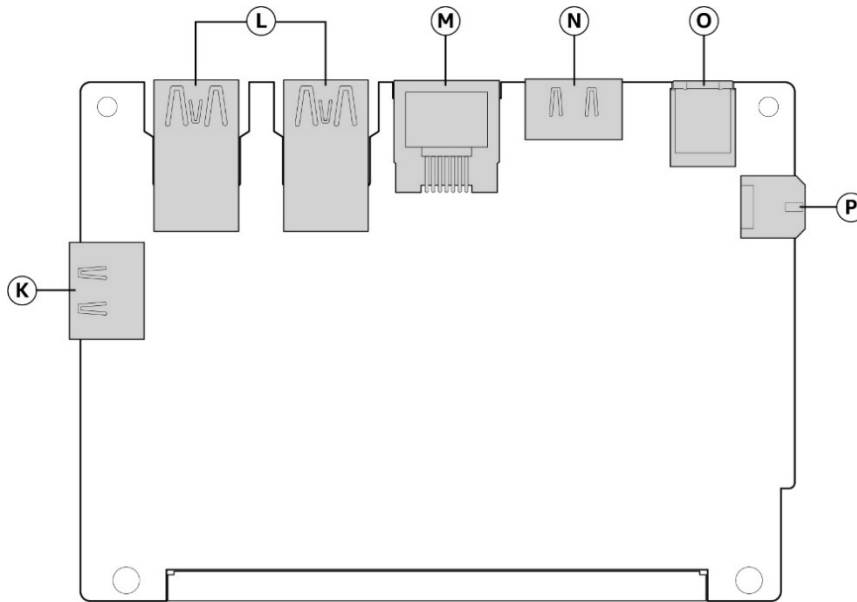

41090

Figure 3. Features (Bottom)

Table 2. Features

Item	Description	Item	Description
A	Battery	I	Wireless Enable/Disable Switch
B	Embedded DisplayPort (eDP) Connector	J	Thunderbolt™ 4 Port (USB4/DP)
C	M.2 Connector	K	HDMI Port
D	System Fan Header (black)	L	USB 3.x ¹ Ports
E	Thermal Solution Fan Header (black)	M	Ethernet Connector (RJ-45)
F	300-pin Connector	N	HDMI Port
G	Front Panel Header	O	Power Input Jack
H	USB 2.0 Headers (white)	P	2x2 Power Input Connector

¹ USB 3.x port speed is determined by the Intel® NUC Compute Element.

2.3 USB 2.0 Headers

The NUC Board Element CMB2GB has two white, 1x4, 1.25mm pitch right angled USB 2.0 headers.

Table 3. USB 2.0 Header Pinout

Pin	Signal Name	Description
1	+5 V DC	Voltage In
2	D-	Data Minus
3	D+	Data Positive
4	GND	Ground

2.4 Fan Headers

The NUC Board Element CMB2GB has two black, 1x4, 1.25mm pitch, right angled fan headers. One fan header is used for the NUC Compute Element thermal solution and the other fan header is used for a system fan.

Table 4. Fan Header Pinout

Pin	Signal Name	Description
1	GND	Ground
2	+5V_S0	Fan Power
3	FAN_TAC	Fan Speed
4	FAN_PWM	Fan Pulse Width Modulation

2.5 Power Input Connector

The NUC Board Element CMB2GB has a 2x2, 1.25mm pitch right angled power input connector.

Table 5. Power Input Connector Pinout

Pin	Signal Name	Description
1	Vin	Voltage In
2	Vin	Voltage In
3	GND	Ground
4	GND	Ground

2.6 Embedded DisplayPort Connector

The NUC Board Element CMB2GB has a 1x40, 0.5mm pitch, right angled Embedded DisplayPort (eDP) connector.

Table 6. eDP Connector Pinout

Pin	Signal Name	Description
1	NC - RESERVED	Reserved for LCD manufacturer's use
2	H_GND	High Speed Ground
3	Lane3_N	Complement Signal Link Lane 3
4	Lane3_P	True Signal Link Lane 3
5	H_GND	High Speed Ground
6	Lane2_N	Complement Signal Link Lane 2
7	Lane2_P	True Signal Link Lane 2
8	H_GND	High Speed Ground
9	Lane1_N	Complement Signal Link Lane 1
10	Lane1_P	True Signal Link Lane 1
11	H_GND	High Speed Ground
12	Lane0_N	Complement Signal Link Lane 0
13	Lane0_P	True Signal Link Lane 0
14	H_GND	High Speed Ground
15	AUX_CH_P	True Signal Auxiliary Channel
16	AUX_CH_N	Complement Signal Auxiliary Channel
17	H_GND	High Speed Ground
18	LCD_VCC	LCD logic and driver power (Vcc3)
19	LCD_VCC	LCD logic and driver power (Vcc3)
20	LCD_VCC	LCD logic and driver power (Vcc3)
21	LCD_VCC	LCD logic and driver power (Vcc3)
22	NC	LCD Panel Self-Test Enable (Optional)
23	LCD_GND	LCD logic and driver ground
24	LCD_GND	LCD logic and driver ground
25	LCD_GND	LCD logic and driver ground
26	LCD_GND	LCD logic and driver ground
27	HPD	HPD signal pin
28	BL_GND	Backlight ground
29	BL_GND	Backlight ground
30	BL_GND	Backlight ground
31	BL_GND	Backlight ground
32	BL_ENABLE	Backlight On/Off
33	BL_PWM_DIM	PWM dimming control signal
34	NC - RESERVED	Reserved for LCD manufacturer's use
35	NC - RESERVED	Reserved for LCD manufacturer's use
36	BL_PWR	Backlight power (+Vin)
37	BL_PWR	Backlight power (+Vin)
38	BL_PWR	Backlight power (+Vin)
39	BL_PWR	Backlight power (+Vin)
40	NC - RESERVED	RESERVED for LCD manufacturer's use

**NOTE**

The eDP solution does not support power input greater than 21V.

2.7 Power Jack

The NUC Board Element has a power jack on the back panel.

- Dual barrel
- 2.5mm inner diameter
- 5.5mm outer diameter

See section **Error! Reference source not found.** for information on power requirements.

2.8 Front Panel Header

The NUC Board Element CMB2GB has a 1x11, 1.25mm pitch, right angle front panel header.

Table 7. Front Panel Header Pinout

Pin	Signal Name	Description
1	POWER_SWITCH#	[In] Power Switch
2	GND	Ground
3	POWER_LED_MAIN	[Out] Front Panel LED (main color)
4	POWER_LED_ALT	[Out] Front Panel LED (alternate color)
5	RSVD	Reserved
6	+5V_DC	Power, 1A (Vcc)
7	RSVD	Reserved
8	HDD_LED-	[Out] HDD activity LED
9	HDD_LED+	[Out] HDD activity LED with current limiting resistor
10	GND	Ground
11	RESET_SWITCH#	[In] Reset Switch

2.9 Power

The NUC Board Element requires a 12-24 \pm 8% V DC input via the back-panel power jack or the internal power connector. Both inputs provide delayed AC start as well as transient voltage suppression (TVS) at 26 V.



NOTE

Total power required will need to consider the NUC Compute Element power requirements, the NUC Board Element CMB2GB power requirements and any devices or peripherals that are plugged into the NUC Board Element CMB2GB.



NOTE

The NUC Assembly Element can power on from the G3/AC power loss state without the Real-Time Clock battery plugged in when a NUC Compute Element is connected.

⚠ CAUTION

It is strongly recommended to make sure that the NUC Board Element CMB2GB is powered off and AC power is removed before removing the NUC Compute Element from the board connector. Removing the NUC Compute Element from the board connector while powered on may cause damage to the NUC Compute Element, operating system corruption, create a no boot condition or result in data loss. If the Blue LED on the board is illuminated, do not remove the NUC Compute Element from the board connector

⚠ CAUTION

Do not remove the AC power source without correctly powering down the NUC Board Element. Removing the AC power source while the NUC Board Element is operating may cause damage to the system, operating system corruption, create a no boot condition, result in data loss or result in unexpected conditions.

2.10 Wireless Enable/Disable Switch

The 2-position switch determines whether the wireless module on the NUC Compute Element is enabled or disabled. Figure 4 shows the location of the switch. Table 8 describes the switch settings.

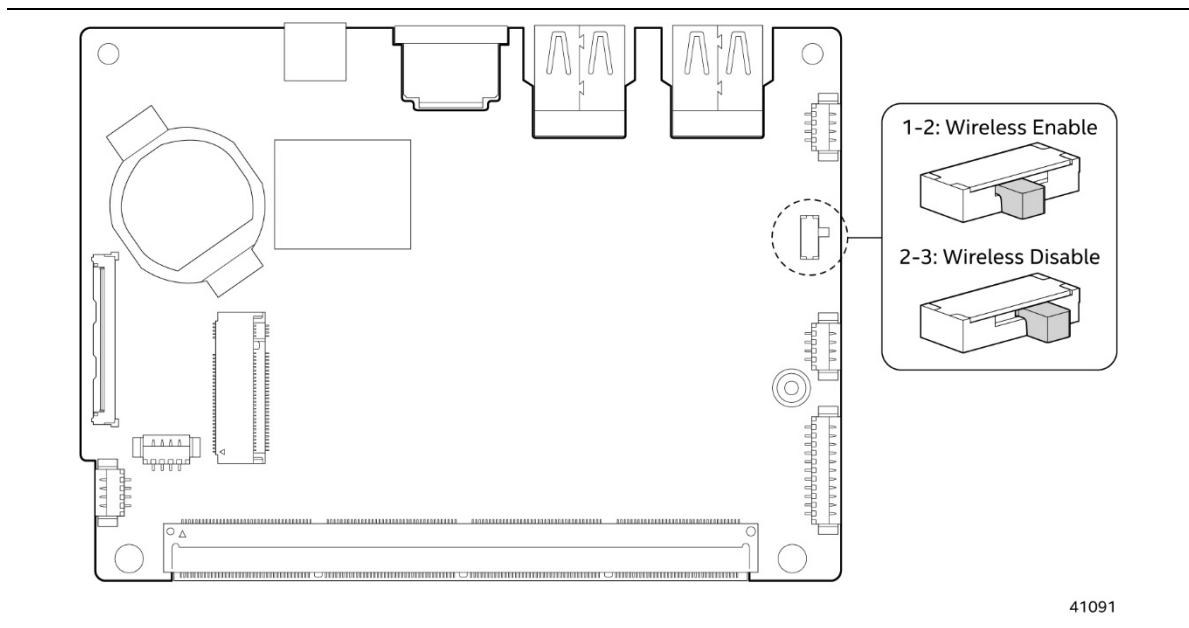

Figure 4. Wireless Enable/Disable Switch Location

Table 8. Wireless Enable/Disable Switch Settings

Function/Mode	Switch Setting	Configuration
Enable	1-2	Wireless and Bluetooth will be enabled on the NUC Compute Element
Disable	2-3	Wireless and Bluetooth will be disabled on the NUC Compute Element

**CAUTION**

Do not change the switch with the power on. Always turn off the power and unplug the power cord from the carrier board before changing a switch setting. Otherwise, the board could be damaged.

2.11 Thunderbolt™ 4

Thunderbolt™ 4 is supported with up to 40 Gbps of data throughput, 5K (60Hz) monitor output, USB 4 connection, charging output capabilities up to 5V at 3A or 9V at 2A via the USB Type C connector on the back panel.

2.12 Intel® vPro® Technology

Intel® vPro™ Technology is a collection of platform capabilities that support enhanced manageability, security, virtualization and power efficiency.

For information about

Intel® vPro® Technology

Refer to<http://support.intel.com/support/vpro/>**NOTE**

Intel® vPro® Technology is only supported on the Intel® NUC Board Element if an Intel NUC Compute Element with Intel® vPro® Technology support is connected.

2.13 Thermal

The fundamental design of the Intel® NUC Compute Element relies on the chassis that the Intel® NUC Board Element CMB2GB is installed into for proper cooling. Both internal components and external skin temperatures are critical parameters in proper cooling and should be considered in any design. For best cooling performance, direct contact with a thermal management device to the bottom of the NUC Compute Element such as a heatsink or enclosure surface is recommended. This can be accomplished with active or passive cooling design approaches. Non-contact convection only cooling may be possible but will likely result in performance limitations or compromises in skin temperature levels relative to a conductive design approach.

The Integrated Heat Spreader side of the NUC Compute Element is the primary heat source. To provide adequate cooling of the NUC Compute Element while maintaining safe skin temperatures a thermal solution that contacts the entire metal portion of the Integrated Heat Spreader is recommended. Localized contact with the primary heat source on the NUC Compute Element bottom is not recommended as the location is subject to change with different generations of the NUC Compute Element. The Mylar side of the NUC Compute Element does not typically require contact with a thermal solution, however proper air flow over the top of the NUC Compute Element is recommended.

For more detailed thermal design information, refer to the NUC Compute Element Carrier Board Design Guide available at [MyIntel](https://www.intel.com/MyIntel).

2.14 Mechanical

The following figure illustrates the mechanical form factor for the Intel® NUC Board Element CMB2GB. Dimensions are given in millimeters (mm).

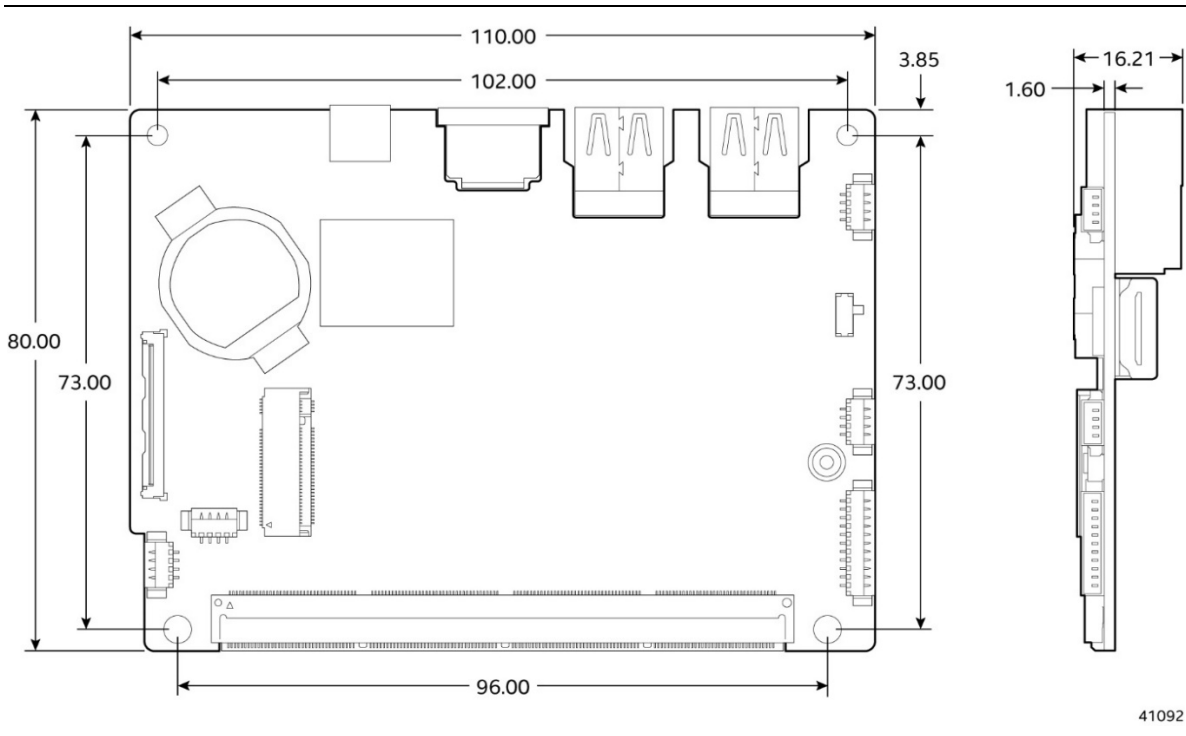

Figure 5. CMB2GB Dimensions

41092

2.15 Environmental

Table 9 lists the environmental specifications for the Intel® NUC Board Element CMB2GB.

Table 9. Environmental Specifications

Parameter	Specification	
Temperature		
Non-Operating	-40 °C to +60 °C	
Operating (Board)	0 °C to +50 °C external ambient (external ambient temperature refers to the temperature at any location measured at 25mm around the NUC Board Element)	
Shock (Board)		
Unpackaged	25 g trapezoidal waveform	
	Velocity change of 250 inches/s ²	
Packaged	Free fall package drop machine set to the height determined by the weight of the package.	
	Product Weight (pounds)	Free Fall (inches)
	<20	36
	21-40	30
	41-80	24
	81-100	18
Vibration (Board)		
Unpackaged	5 Hz to 20 Hz: 0.01 g ² /Hz sloping up to 20 Hz @ 0.02 g ² /Hz	
	20 Hz to 500 Hz: 0.02 g ² /Hz (flat)	
	Input acceleration is 3.13 g RMS	

Note: Before attempting to operate this Intel® NUC Board Element CMB2GB, the overall temperature of the system must be above the minimum operating temperature specified. It is recommended that the NUC Board Element CMB2GB temperature be at least room temperature before attempting to power on the system. The operating and non-operating environment must avoid condensing humidity.

3 Characterized Errata

This section of the document communicates product Errata for the Intel® NUC Board Element CMB2GB.

Errata are design defects or deviations from current published specifications for a given product. Published errata may or may not be corrected. Hardware and software designed to be used with any given processor stepping must assume that all errata documented for that process stepping are present on all devices.

There are no known characterized errata.